

Model		LGH-50RVX-E							
Electrical power supply		220-240V/50Hz, 220V/60Hz							
Ventilation mode		Heat recovery mode				Bypass mode			
Fan speed		SP4	SP3	SP2	SP1	SP4	SP3	SP2	SP1
Running current (A)		1.15	0.59	0.26	0.13	1.15	0.59	0.27	0.13
Input power (W)		165	78	32	12	173	81	35	14
Air volume	(m³/h)	500	375	250	125	500	375	250	125
	(L/s)	139	104	69	35	139	104	69	35
External static pressure (Pa)		120	68	30	8	120	68	30	8
Temperature exchange efficiency (%)		78.0	81.0	83.5	87.0	—	—	—	—
Enthalpy exchange efficiency (%)	Heating	69.0	71.0	75.0	82.5	—	—	—	—
	Cooling	66.5	68.0	72.5	82.0	—	—	—	—
Noise (dB) (Measured at 1.5m under the center of unit in an anechoic chamber)		34.0	28.0	19.0	18.0	35.0	29.0	20.0	18.0
Weight (kg)		33							

\*The Air outlets noise (45 angle, 1.5meters in front of the unit) is about 18dB greater than the indicated value.(at Fan speed 4)

\*The running current, the input power, the efficiency and the noise are based on the rating air volume, and 230V/50Hz.

\*For the specification at the other frequency contact your dealer.

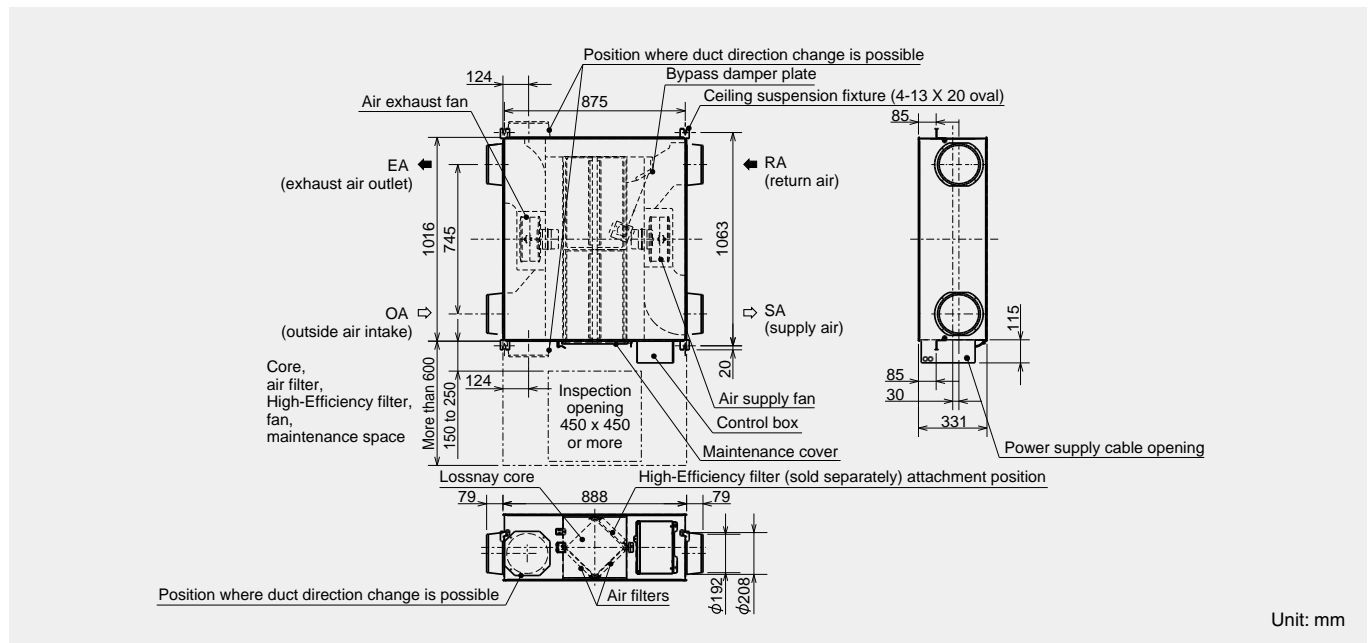
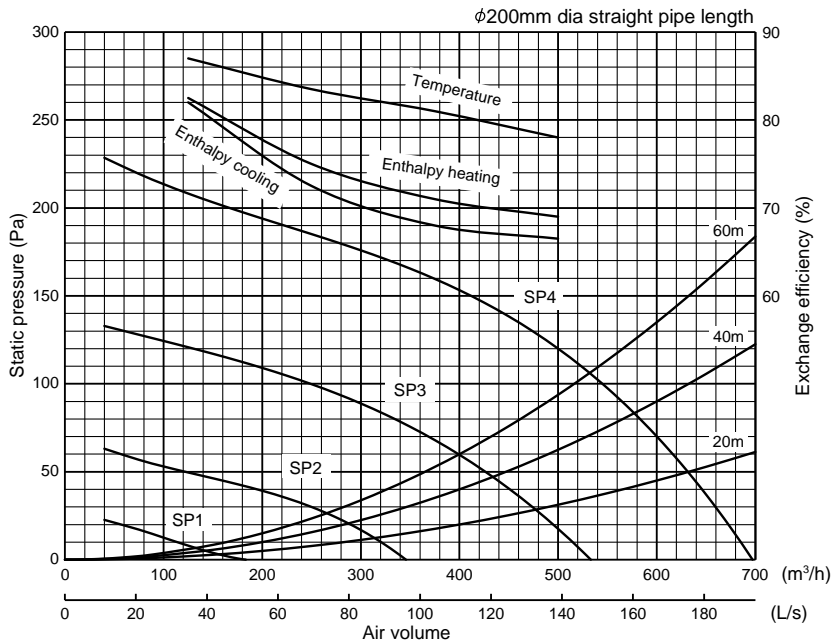

Unit: mm